

Rubiq Monobloc Sink Mixer with 'U' Spout

- 1/4 turn ceramic disc flow control
- Vernier insert for accurate handle alignment
- Unique handle construction with integral bearing ring
- Flexible connectors for easier installation

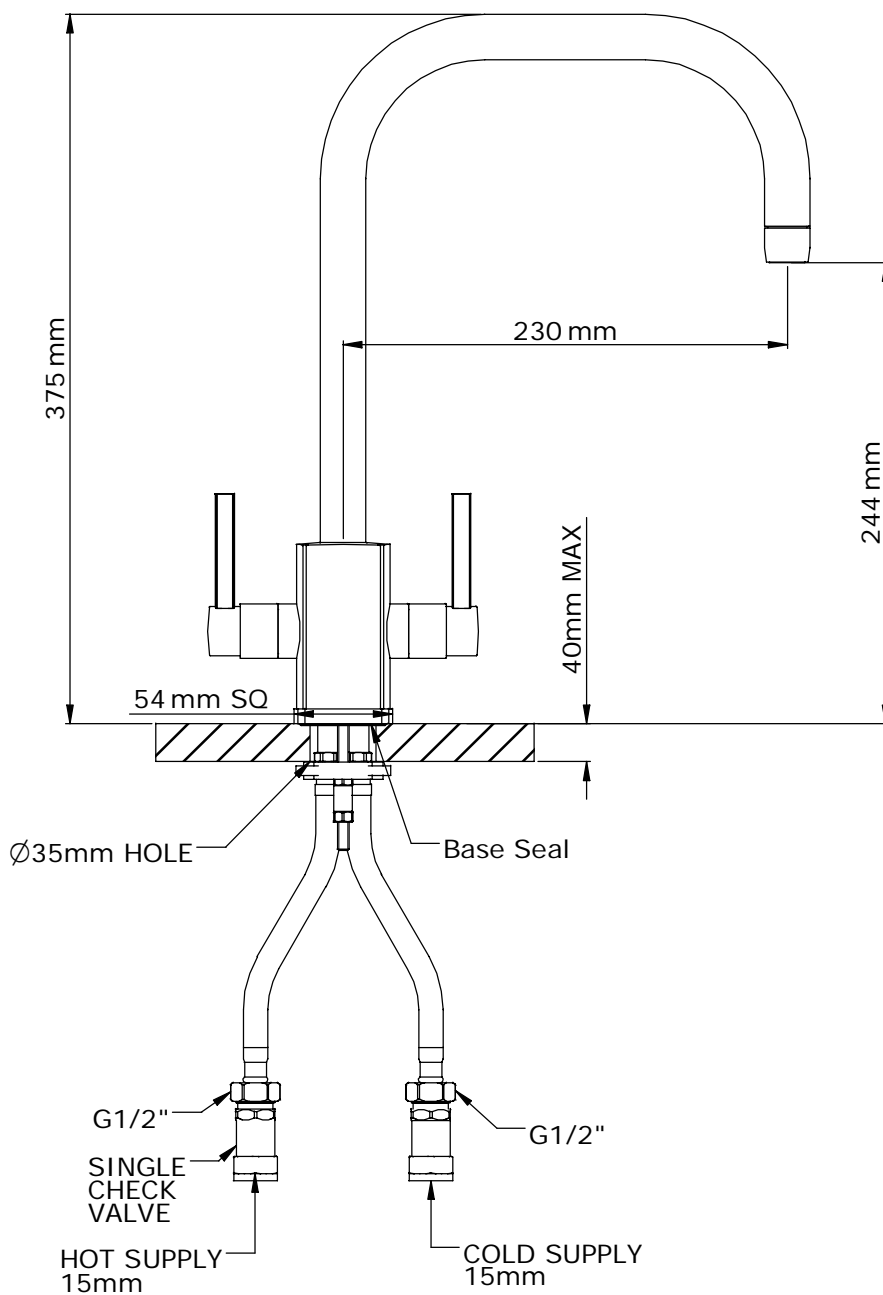

Available Finishes:

- Chrome
- Nickel
- Pewter

Temp Range:

Min 1°C / 34°F
Max 85°C / 185°F

Recommended Working Pressure:

Min 1bar / 15psi

Rubiq Monobloc Sink Mixer with 'U' Spout

SPARES

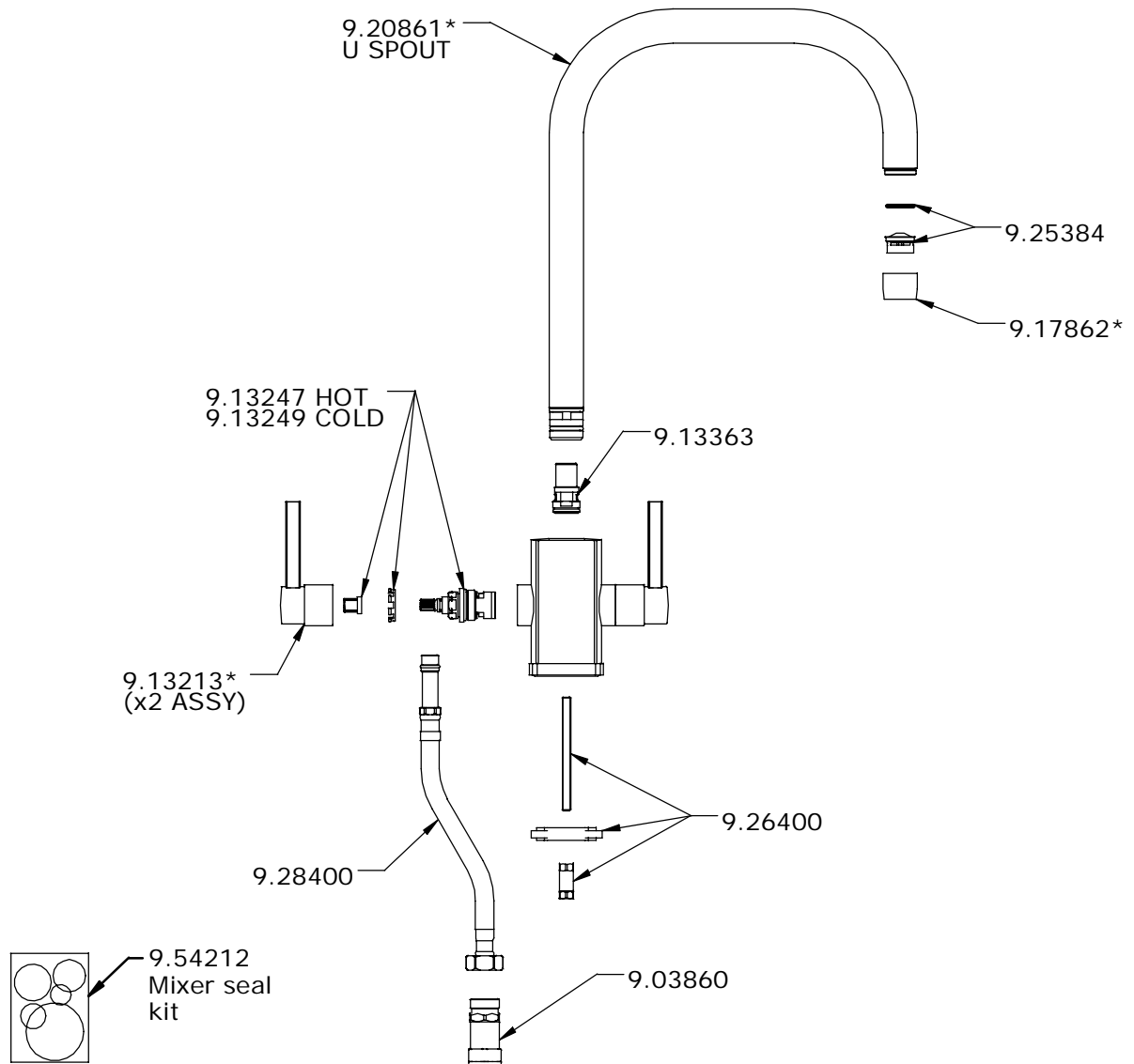

* Where indicated please specify colour