

POLARIS (3-in-1) INSTANT HOT SINK MIXER

- Open vented system
- Digital temperature control accurate to 0.5°C
- Multiple pre-set temperatures ranging from 75°C to 98°C
- High quality nano filtration technology with limescale reduction
- 2.4 Litre capacity
- 1.5Kw element
- Anti-scald lock
- Spring-back valve
- Minimal heat loss

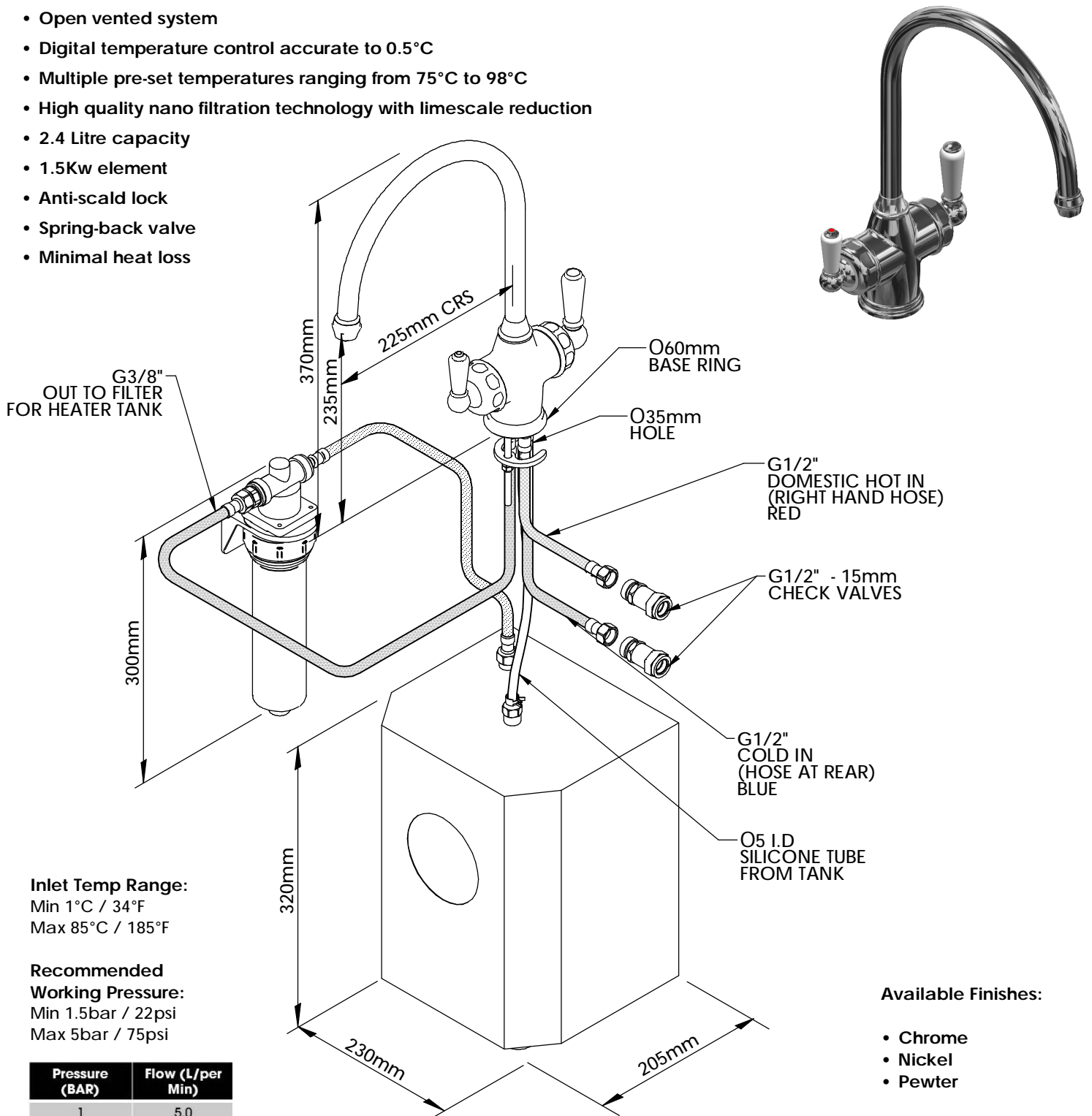

Inlet Temp Range:
Min 1°C / 34°F
Max 85°C / 185°F

Recommended Working Pressure:
Min 1.5bar / 22psi
Max 5bar / 75psi

Pressure (BAR)	Flow (L/per Min)
1	5.0
2	7.6
3	9.2
4	11

Available Finishes:

- Chrome
- Nickel
- Pewter

Pressure Reducing Valve (PRV) required if inlet pressure is in excess of 5bar.
Contact our team to order our recommended PRV 9.13303.

POLARIS (3-in-1) INSTANT HOT SINK MIXER

* Where indicated specify colour

